



+44 (0)1454 319524  
 sales@stedall.co.uk  
 www.stedall.co.uk

# Ramp Springs

## Ratchet Tensioner – Bolt On

Part No.	A	B	C	D	E	F	G	H	Finish
2008	mm265	130	75	55	70				Zinc Plated

Does not require fixing to rear of pillar  
 Unit bolts to front of pillar  
 Pull handle for freewheel action  
 Supplied in pairs

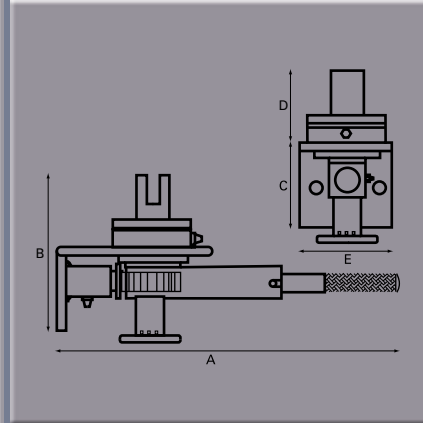

## The 'Foulger' Ramp Spring

Part No.	A	B	C	D	E	F	G	H	Item
6386-1R/H	mm	1175.0	55						Right hand complete spring
6386-1L/H	mm	1175.0	55						Left hand complete spring
6386-B-RH									Right hand top bracket
6386-B-LH									Left hand top bracket
6386-BB-RH									Right hand complete base block
6386-BB-LH									Left hand complete base block
6386-1S									Spring only
6386-J									J bolt only

Capacity per spring 75Kgs

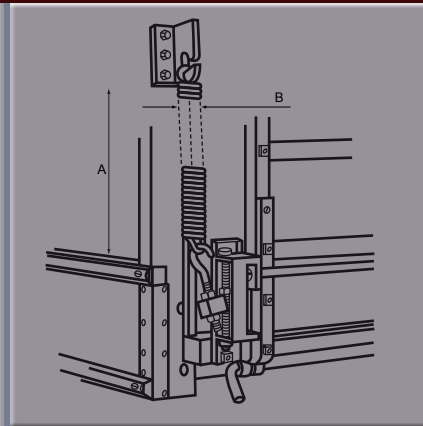

## Drews Type Ramp Spring

Part No.	A	B	C	D	E	F	G	H	Item
6383	mm825	90	110	145	40				Complete unit as shown
6384	mm700	75							Replacement spring only

Capacity per spring: 90kg  
 Stroke: 115mm  
 Plate: 60mm wide

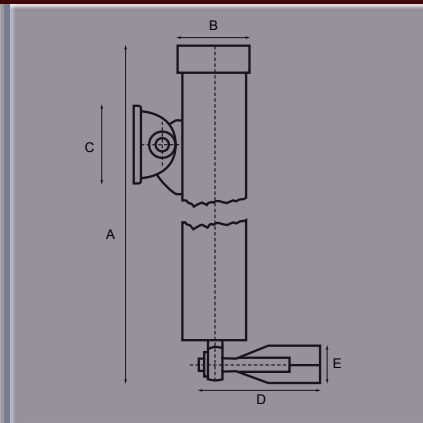

## Underslung Ramp Fittings

Part No.	A	B	C	D	E	F	G	H	Item
6385	mm330	875	110						Complete unit as shown
6384	mm700	75							Replacement spring only

Capacity per spring: 90kg  
 Stroke: 115mm  
 Plate: 60mm wide

